

BelGAS Metal-to-Metal Seat Needle Valves

These 316 stainless steel valves are ideally suited for applications when caustic and corrosive material are being used. Pressure ratings to 10,000 psi (70,000 kPa).

- "T" bar handle
- Teflon* packing
- Roll-formed stem threads
- Precision-machined stem
- Bonnet locking pin prevents accidental removal
- Below stem thread packing gland
- Hardened and ground self centering, non-rotating tip
- Metal-to-Metal seat
- Pressure rating, 10,000 psi (70,000 kPa)



Specifications and Description

Body and Bonnet Material	ASTM A182F 316 stainless steel or ASTM A105 forged single piece steel, plated
Stem Material	316 Stainless Steel
Pressure/ Temperature Rating	10,000 PSI (70,000 kPa) @ 100°F [38°C]
	4000 PSI (28,000 kPa) @ 500°F [260°C]
	Optional Graphite Packing (HT) 10,000 PSI (70,000 kPa) @ 400°F [204°C]
	Alloy Steel 1500 PSI (10,400 kPa) @ 850°F [460°C]
	316 Stainless Steel 1500 PSI (10,400 kPa) @ 1000°F [538°C]
Packing	Two piece molded Teflon* (PTFE).
Seat	Metal-to-Metal
Handle	"T" bar; 316 Stainless Steel or ASTM A108 Alloy Steel
Connection	National Pipe Thread, meeting specifications of ANSI B2.1
Finish	Stainless Steel is Passivated. Alloy Steel has a clear Zinc Dichromate finish.
* Teflon is a registered trademark of DuPont.	
** NACE valves are manufactured of 316 SS.	

Pattern	Size NPT	Part Number		C _v
		316 SST	Carbon	
FFG	1/8	VHS-FFG-18	VHC-FFG-18	0.40
	1/4	VHS-FFG-14	VHC-FFG-14	0.40
	3/8	VHS-FFG-38	VHC-FFG-38	0.90
	1/2	VHS-FFG-12	VHC-FFG-12	1.10
	3/4	VHS-FFG-34	VHC-FFG-34	2.30
	1	VHS-FFG-01	VHC-FFG-01	3.50
MFG	1/4	VHS-MFG-14	VHC-MFG-14	0.40
	1/2	VHS-MFG-12	VHC-MFG-12	1.20
	3/4 x 1/2	VHS-MFG-3412	VHC-MFG-3412	1.90
FFA	1/8	VHS-FFA-18	VHC-FFA-18	0.70
	1/4	VHS-FFA-14	VHC-FFA-14	0.80
	3/8	VHS-FFA-38	VHC-FFA-38	1.60
	1/2	VHS-FFA-12	VHC-FFA-12	2.20
	3/4	VHS-FFA-34	VHC-FFA-34	2.20
MFA	1	VHS-FFA-01	VHC-FFA-01	2.20
	1/4	VHS-MFA-14	VHC-MFA-14	0.60
	1/2	VHS-MFA-12	VHC-MFA-12	1.50

Option	Suffix
Graphite Packing - High Temp.	H
NACE**	N
Panel Mount	P

BelGAS Soft-Seat Needle Valves

For applications where bubble-tight shutoff of liquids or gases are required. Pressure rating to 6,000 psi (42,000 kPa). These valves are designed with a replaceable Delrin[™] soft seat.

- "T" bar handle
- Teflon^{*} packing
- Roll-formed stem threads
- Precision-machined stem
- Bonnet locking pin prevents accidental removal
- Below stem thread packing gland
- Hardened and ground self-centering, non-rotating tip
- Soft-Seat
- Bubble-tight shutoff of liquids or gases to 6,000 psi (42,000 kPa)



Specifications and Description

Body and Bonnet Material	ASTM A182F 316 Stainless Steel or ASTM A105 forged single piece steel, plated.
Stem Material	316 Stainless Steel
Pressure/ Temperature Rating	6000 PSI (42,000 kPa) @ 100°F [38°C]
	4000 PSI (28,000 kPa) @ 500°F [260°C]
	Optional Graphite Packing (HT) 6000 PSI (42,000 kPa) @ 400°F [204°C]
	Alloy Steel 1500 PSI (10,400 kPa) @ 850°F [460°C]
Packing	316 Stainless Steel 1500 PSI (10,400 kPa) @ 1000°F [538°C]
	Two piece molded Teflon [*] (PTFE)
Seat	Delrin [™] Soft-Seat.
Handle	"T" bar; 316 Stainless Steel or ASTM A108 Alloy Steel
Connection	National Pipe Thread, meeting specifications of ANSI B2.1
Finish	Stainless Steel is Passivated. Alloy Steel has a clear Zinc Dichromate finish
Stem Retaining Method	All valves feature integral back-seated stem for preventing accidental removal
Assembly	Bonnet is threaded into body and pinned into place
<small>* Teflon is a registered trademark of DuPont [™] Delrin is a registered trademark of DuPont ^{***} NACE valves are manufactured of 316 SS</small>	

Pattern	Size NPT	Part Number		C _v
		316 SST	Carbon	
FFG	1/4	VSS-FFG-14	VSC-FFG-14	0.60
	1/2	VSS-FFG-12	VSC-FFG-12	0.70
	3/4	VSS-FFG-34	VSC-FFG-34	2.35
	1	VSS-FFG-01	VSC-FFG-01	2.00
MFG	1/4	VSS-MFG-14	VSC-MFG-14	0.60
	1/2	VSS-MFG-12	VSC-MFG-12	0.70
	1/4 x 1/2	VSS-MFG-1412	VSC-MFG-1412	0.80
MFA	1/4	—	VSC-MFA-14	0.70
	1/2	—	VSC-MFA-12	0.70

Option	Suffix
Graphite Packing - High Temp.	H
NACE ^{***}	N
Panel Mount	P

Needle Valves Patterns and Dimensions

Metal-to-Metal - 316 Stainless Steel or Alloy

FFG and MFG

Double Female and Male/Female Globe Pattern

Dimension	Nominal Sizes (inches [mm])					
	1/8	1/4	3/8	1/2	3/4	1
A	3.39 [86.0]	3.39 [86.0]	3.46 [88.0]	3.62 [92.0]	3.66 [93.0]	4.41 [112.0]
B		1.18 [30.0]		1.26 [32.0]	1.26 [32.0]	1.69 [43.0]
CF	2.36 [60.0]	2.36 [60.0]	2.68 [68.0]	2.68 [68.0]	2.68 [68.0]	3.15 [80.0]
CM		2.99 [76.0]		3.50 [89.0]	3.50 [89.0]	4.13 [105.0]
E	1.12 [28.5]	1.12 [28.5]	1.26 [32.0]	1.50 [38.0]	1.57 [40.0]	1.77 [45.0]
Orifice	0.17 [4.2]	0.17 [4.2]	0.25 [6.4]	0.28 [7.0]	0.35 [9.0]	0.47 [12.0]

FFA and MFA

Double Female and Male/Female Angle Pattern

Dimension	Nominal Sizes (inches [mm])					
	1/8	1/4	3/8	1/2	3/4	1
A	3.39 [86.0]	3.39 [86.0]	3.39 [86.0]	3.62 [92.0]	3.62 [92.0]	4.41 [112.0]
C	1.65 [42.0]	1.65 [42.0]	1.65 [42.0]	1.97 [50.0]	1.97 [50.0]	2.36 [60.0]
E	1.10 [28.0]	1.10 [28.0]	1.10 [28.0]	1.26 [32.0]	1.42 [36.0]	1.81 [46.0]
F	1.65 [42.0]	1.65 [42.0]	1.65 [42.0]	1.97 [50.0]	1.97 [50.0]	2.36 [60.0]
Orifice	0.17 [4.2]	0.17 [4.2]	0.25 [6.4]	0.28 [7.0]	0.35 [9.0]	0.47 [12.0]

Soft-Seat - 316 Stainless Steel or Alloy

FFG and MFG

Double Female and Male/Female Globe Pattern

Dimension	Nominal Sizes (inches [mm])			
	1/4	1/2	1/4 x 1/2	1
A	3.39 [86.0]	3.62 [92.0]	3.62 [92.0]	4.41 [112.0]
B	1.18 [30.0]	1.26 [32.0]		1.26 [32.0]
CF	2.36 [60.0]	2.68 [68.0]		3.15 [80.0]
CM	2.99 [76.0]	3.50 [89.0]	3.50 [89.0]	
E	1.12 [28.5]	1.26 [32.0]	1.50 [38.0]	1.77 [45.0]
Orifice	0.17 [4.2]	0.28 [7.0]	0.28 [7.0]	0.47 [12.0]

MFA

Male/Female Angle Pattern

Dimension	Nominal Sizes (inches [mm])	
	1/4	1/2
A	3.39 [86.0]	3.62 [92.0]
C	1.65 [42.0]	1.97 [50.0]
E	1.10 [28.0]	1.26 [32.0]
F	1.65 [42.0]	1.97 [50.0]
Orifice	0.17 [4.2]	0.28 [7.0]

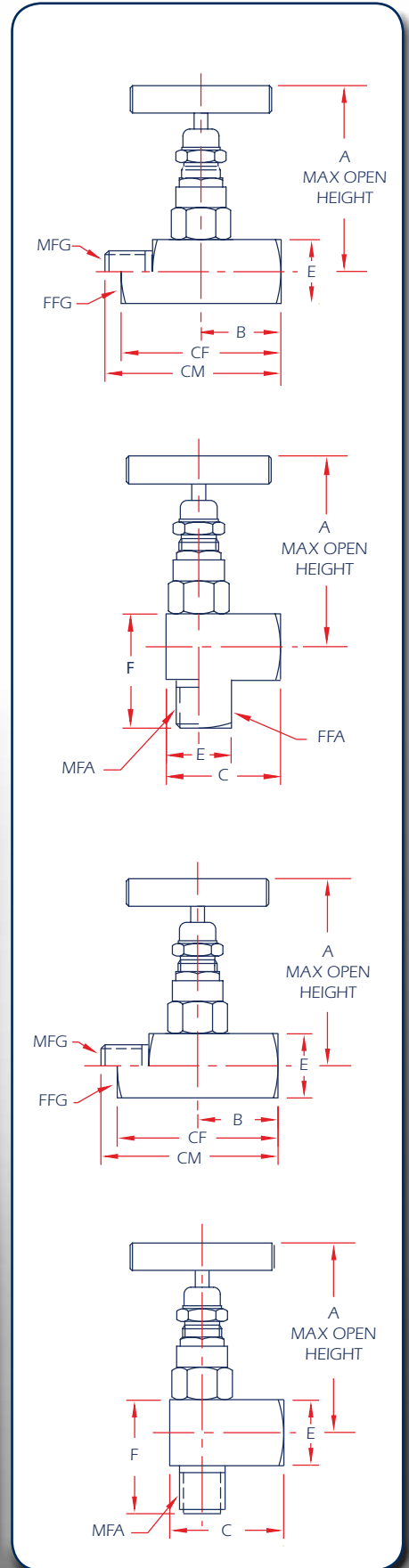

BelGAS Block/Bleed Needle Valves

Ideally used to isolate gauge legs and gauge reading, allow sampling to take place without loss of material and provide extra pressure ports with isolation capabilities and can be used only when needed.

- "T" Bar Handle
- Teflon^{*} Packing
- Roll-Formed Stem Threads
- Precision-Machined Stem
- Below Stem Thread Packing Gland
- Hardened and Ground 316 Stainless Steel, Self-Centering, Non-Rotating Tip
- Carbon Steel or 316 SST Port Plug
- Pressure Rating, 10,000 PSI (70,000 kPa)

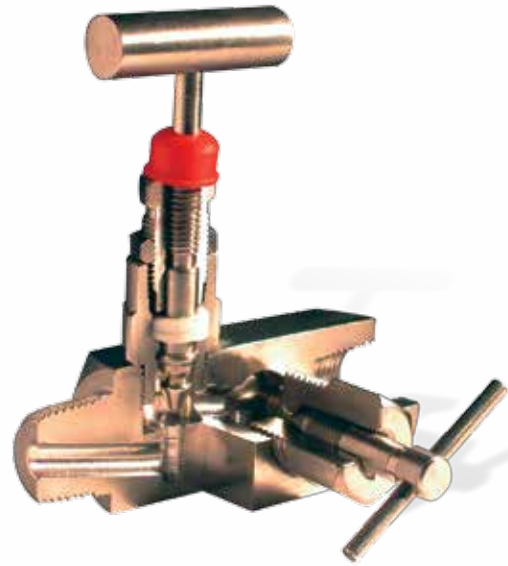

Specifications and Description

Body and Bonnet Material	ASTM A182F 316 Stainless Steel or ASTM A105 forged single piece steel, plated
Stem Material	316 Stainless Steel
Pressure/ Temperature Rating	10,000 PSI (70,000 kPa) @ 100°F [38°C]
	4000 PSI (28,000 kPa) @ 500°F [260°C]
	Optional Graphite Packing (HT) 10,000 PSI (70,000 kPa) @ 400°F [204°C]
	Alloy Steel 1500 PSI (10,400 kPa) @ 850°F [460°C]
	316 Stainless Steel 1500 PSI (10,400 kPa) @ 1000°F [538°C]
Packing	Two piece molded Teflon [*] (PTFE)
Seat	Metal-to-Metal
Handle	"T" Bar; 316 Stainless Steel or ASTM A108 Alloy Steel
Connection	National Pipe Thread, meeting specifications of ANSI B2.1
Finish	Stainless Steel is Passivated. Alloy Steel has a clear Zinc Dichromate finish
Stem Retaining Method	All valves feature integral back-seated stem for preventing accidental removal
Assembly	Bonnet is threaded into body and pinned into place.

^{*} Teflon is a registered trademark of DuPont.

Pattern	Size NPT	Part Number		C _v
		316 SST	Carbon	
Block/Bleed	1/2 x 1/2	BHS-MFG-12	BHC-MFG-12	0.40
	3/4 x 1/2	BHS-MFG-3412	BHC-MFG-3412	0.40

Option	Suffix
Graphite Packing - High Temp.	H

Dimension	Nominal Size (inches [mm])	
	1/2	3/4 x 1/2
A	3.54 [90.0]	3.54 [90.0]
B	1.50 [38.0]	1.50 [38.0]
C	3.74 [95.0]	3.74 [95.0]
Orifice	0.28 [7.0]	0.28 [7.0]

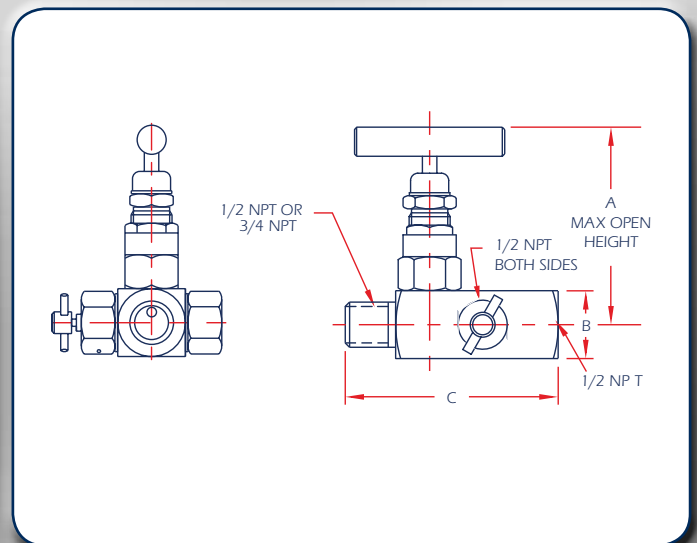
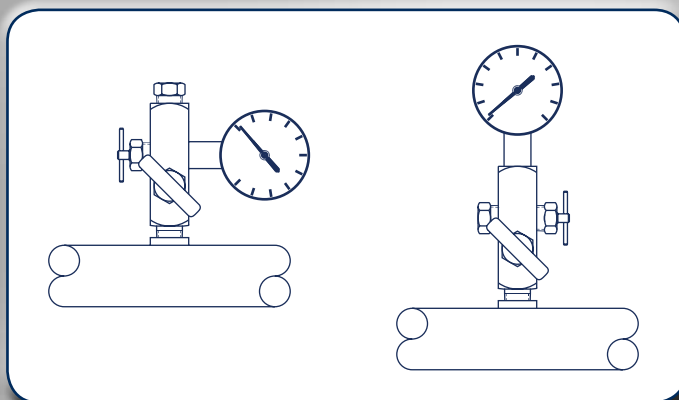

BelGAS Miniature Needle Valves

Miniature size for applications where space is limited.
Ideal for test stand and general equipment.

- "T" Bar Handle or Thumb Wheel
- Roll-Formed Stem Threads
- Precision-Machined Stem
- Teflon^{*} Packing
- Bonnet Locking Pin Prevents Accidental Removal
- Metal-to-Metal and Soft Seat
- Pressure Rating, 6,000 PSI (42,000 kPa)



Specifications and Description

Body and Bonnet Material	ASTM A479 316 Stainless Steel or ASTM A108 Barstock Steel, Plated
Stem Material	316 Stainless Steel
Bonnet Cap (Protective Cover)	Low Density Polyethylene, Red
Pressure/ Temperature Rating	6000 PSI (42,000 kPa) @ 100°F [38°C]
	4000 PSI (28,000 kPa) @ 500°F [260°C]
Packing	Molded Teflon [*] (PTFE)
Seat	Metal-to-Metal and Delrin ^{**} Soft-Seat
Handle	"T" Bar; 316 Stainless Steel / ASTM A108 Alloy Steel / Aluminum Anodized Thumb Wheel
Connection	National Pipe Thread, meeting specifications of ANSI B2.1
Finish	Stainless Steel is Passivated. Alloy Steel has a clear Zinc Dichromate finish
Stem Retaining Method	All valves feature integral back-seated stem for preventing accidental removal
Assembly	Bonnet is threaded into body and pinned into place
[*] Teflon is a registered trademark of DuPont. ^{**} Delrin is a registered trademark of DuPont.	

Pattern	Size NPT	Part Number		Seat	C _v
		316 SST	Carbon		
FFG	1/8	MHS-FFG-18	MHC-FFG-18	Hard	0.25
	1/8	MHS-FFG-18W	MHC-FFG-18W	Hard	0.25
	1/4	MHS-FFG-14	MHC-FFG-14	Hard	0.25
	1/4	MHS-FFG-14W	MHC-FFG-14W	Hard	0.25
MFG	1/4	MHS-MFG-14	MHC-MFG-14	Hard	0.25
	1/4	MHS-MFG-14W	MHC-MFG-14W	Hard	0.25
	1/4	MSS-MFG-14	MSC-MFG-14	Soft	0.25
	1/4	MSS-MFG-14W	MSC-MFG-14W	Soft	0.25

Standard is T-bar – 'W' is thumb wheel

Dimension	Nominal Size (inches [mm])	
	1/8	1/4
A	2.44 [62.0]	2.44 [62.0]
B	0.87 [22.0]	0.87 [22.0]
C	1.89 [48.0]	1.89 [48.0]
Orifice	0.13 [3.2]	0.13 [3.2]

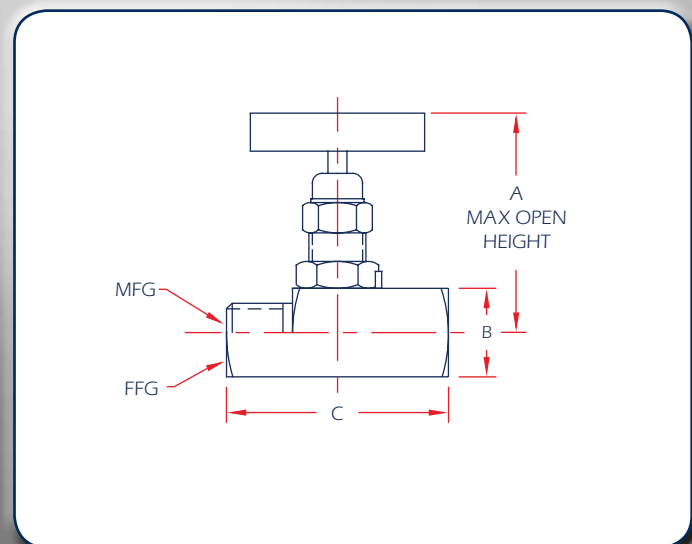

Notes:

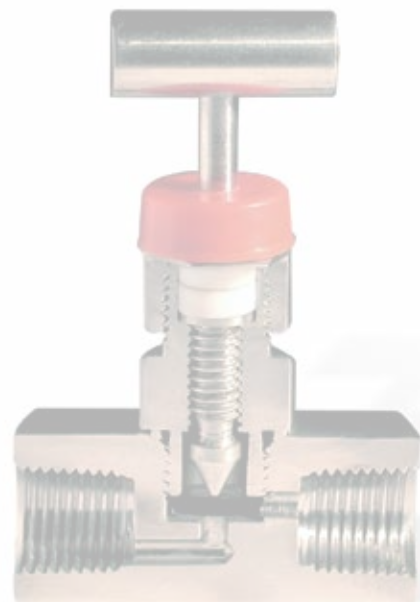

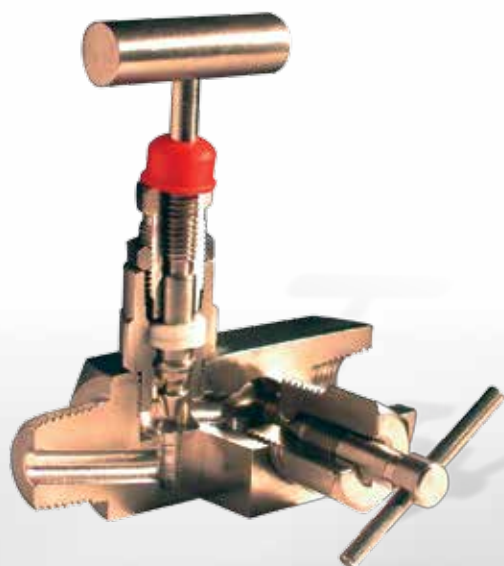

BelGAS, the leader in pressure regulator design, offers the Oil, Gas and Pipeline Industry the same precision and reliability in flow control and pressure control that the control valve market has enjoyed for over 40 years. At BelGAS, we have raised the industry standard for quality, accuracy, and dependability. Even more important is that we provide this value to our customers at an economical price.

The BelGAS product offering includes pressure regulators for gas, air and propane service; explosion-proof I/P transducers for electro-pneumatic applications; process and test gauges for pressure measurement in general and severe service and a wide assortment of bimetal thermometers and thermowells for both high and low temperature indication.

Whether the requirements call for a high pressure flow condition, a low pressure relief application or the regulation of fuel or process gas in a system, BelGAS can provide a dependable and cost effective solution.

Mountain Controls



COPPUS®
Air Movers

Portable Ventilators
Fans & Blowers
Welding Fume Exhausters
Mist Coolers & Duct



A-T Controls, Inc.

Ball Valves and Actuators
Spring Return Electric Actuators
Resilient Seated Butterfly Valves
High Performance Butterfly Valves



MARSH®

Pressure Gauges
Thermometers
Needle Valves and Diaphragm Seals



BELLOFRAM
Precision Controls

Precision Air Regulators
Air, Gas, Steam & Water Regulators
Vacuum and Backpressure Regulators
I/P and E/P Transducers

BelGAS

Temperature Indicators
Temperature Switches
Capillary Bulb Type

Marshalltown-Tempco

MOORE INDUSTRIES
WORLDWIDE

Process Controllers
Multi-Loop
Process Indicators with Switches

POWERS PROCESS CONTROLS
Quality...Our Commitment

Control Valves – Globe Type
Temperature Regulators
Self Contained
Temperature Controllers

RCS

Electric Actuators
Modulating Controllers
Spring Return – SURE
Mounting to your valves.

SVF
Flow Controls, Inc.

Ball Valves – 3-piece
Pneumatic Actuators
Electric Actuators
Specialty Valves

G C
VALVES

Solenoid Valves
Water – Air – Hot Water – Steam
Pilot Valves

Valve Actuator Mounting

We stock electric actuators and can provide the mounting and testing to the valve of your choice

Mountain Controls

Mail: mountaincontrolsinc@gmail.com Web: www.mountaincontrols.com
Phone: 801-487-8795 Fax: 801-487-8798
Salt Lake City, UT 84109