



Main Features

- For corrosive gasses and liquids
- Class 1 according to EN 13190
- Capillary 0.5 to 30 m
- Mechanical or inductive contacts
- Wetted parts and case material stainless steel
- Option : case material 1.4404 (316L) for aggressive atmosphere

Applications

- Food & Beverage
- Oil & Gas / Chemical
- Laboratory & Medical
- Energy

Technical Data

Nominal size	100, 160 mm
Temperature ranges	-200 ... 800 °C
Accuracy	Class 1 (according to EN 13190)
Protection rating	IP 65 (EN 60529)
Immersion tube	Stainless steel 1.4541 (AISI 321)
Capillary	Stainless steel 1.4541 (AISI 321) max. length 30 m
Bezel ring	Stainless steel 1.4301 (AISI 304)
Window	Laminated safety glass
Movement	Brass
Window gasket	Elastomer
Dial	Aluminium, white
Pointer	Aluminium, black
Accessories	Sliding connections and thermowells, see data-sheets: B51.01 (AGF/AGW) and T6.215 (Ø 8)
Temperature limit	130 % F.S.

ATEX

Only for inductive contacts (type 8xxx)

Type examination certificate

DEKRA 14 ATEX 0034

EN 60079-0 : 2009

EN 60079-11 : 2007

EN 61241-11 : 2006

Marking

CE 0344

Ex II 2 G

Ex ia IIC T4 Gb

Ex II 2 D

Ex ia IIIC T135 °C ... T85 °C Db

Electrical data

U_{max} = 20 Vdc

I_{max} = 60 mA

P_{max} = 130 mW

Sensor type: SI2-K08-Y1 (Turck)

This certification is valid for connection to a certified intrinsically safe circuit with maximum values as listed above and in the instructions and certificate of the sensor.

Options

Stainless steel housing 1.4404 (316L)	Code 0110	Customer specific immersion length ⁽¹⁾	Code 9003_xxxx
Movement stainless steel	Code 0651	Red mark	Code 9700
Process connections (see table on page 4/5)	Code 73xx	Green mark	Code 9701
Oil filling (paraffin oil, Ondina)	Code 0777	Stainless steel tag plate and wire	Code 9941
Screws secured with loctite	Code 0799		
Accuracy +/- 0.6 % F.S.	Code 0840		

⁽¹⁾ xxxx = L in mm.

Dimensions in mm

Type D (Code 11)

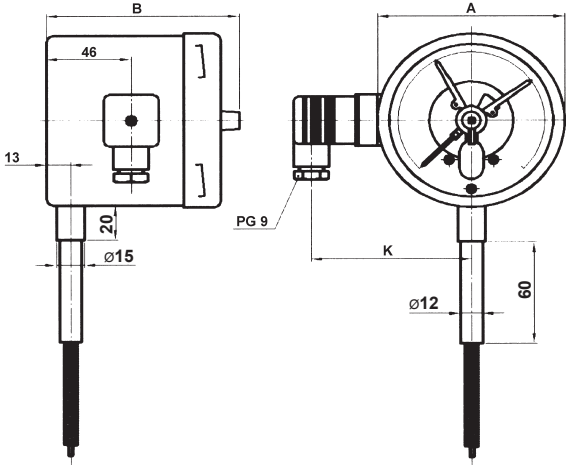

Dimensions	Diameter	
	100	160
A	101	161
B	104	108
K	92	122

Type C (Code 21)

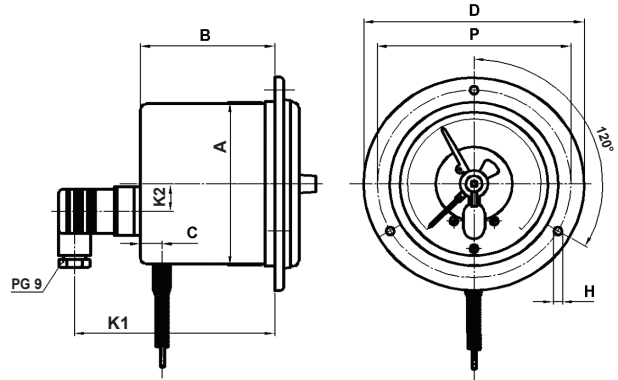

Dimensions	Diameter	
	100	160
A	101	161
B	80	83
C	13	13
D	132	196
H	5.5	6
P	116	178
K1	92	122
K2	15	0

Type B (Code 22)

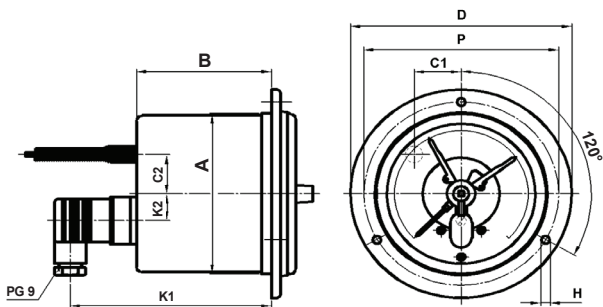

Dimensions	Diameter	
	100	160
A	101	161
B	80	83
C1	26	0
C2	10	0
D	132	196
H	5.5	6
P	116	178
K1	123	126
K2	15	0

Dimensions	Diameter	
	100	160
A	101	161
B	110	114
C	19	19
D	132	196
H	5.5	6
P	116	178
K	92	122

Type A (Code 31)

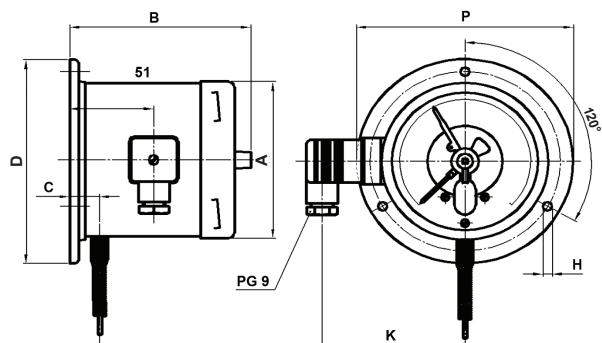

Dimensions in mm

Type E (Code 32)

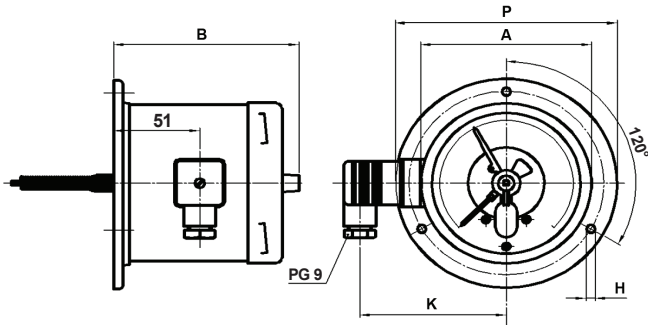

Dimensions	Diameter	
	100	160
A	101	161
B	110	114
D	132	196
H	5.5	6
P	116	178
K	92	122

Type G (Code 53)

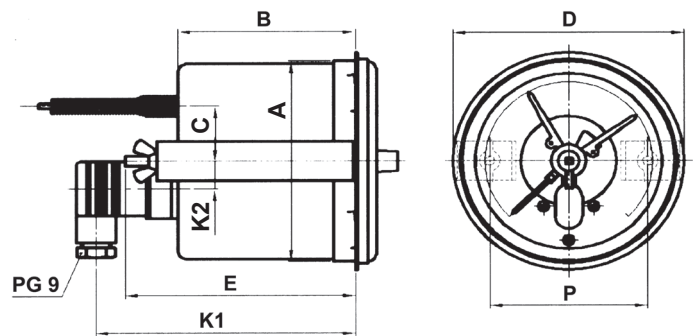

Dimensions	Diameter	
	100	160
A	101	161
B	84	88
C	25	0
D	112	180
E	109	113
P	75	139
K1	128	131
K2	15	54

Type D (Code 61)

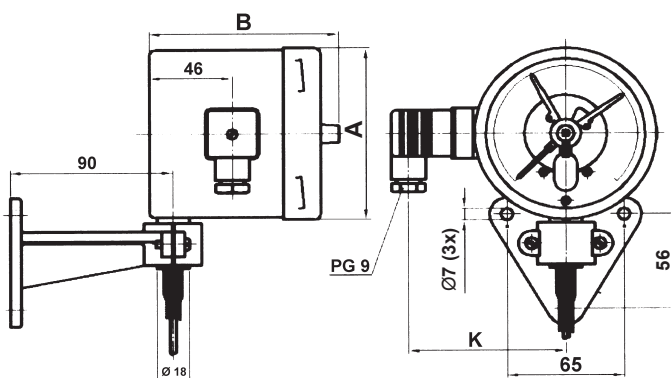

Dimensions	Diameter	
	100	160
A	101	161
B	104	108
K	92	122

Types of capillary

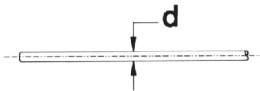
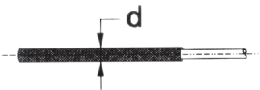
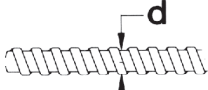
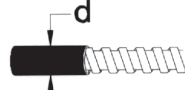
Type	Code	Models	Ø d in mm	Tmin in °C	Tmax in °C
Stainless steel 1.4541 (321) without protection	6		2	- 250	+ 800
Stainless steel 1.4541 (321) with PVC coating	7		4	- 60	+ 120
Stainless steel 1.4541 (321) with stainless steel protection 1.4301 (304)	B		6	- 260	+ 800
Stainless steel 1.4541 (321) with stainless steel protection 1.4301 (304) and PVC coating	C		7.5	- 60	+ 120

Process connections

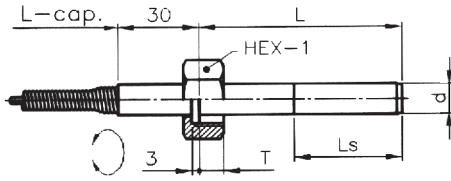
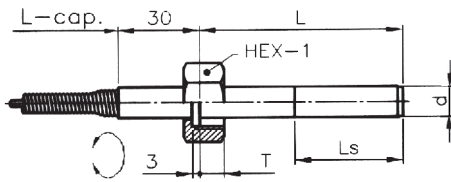
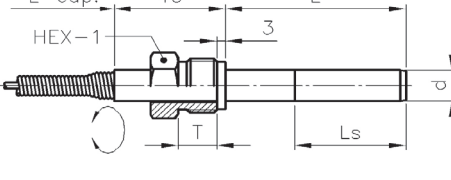
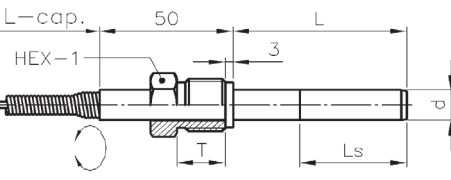
Models	Code	Connection	HEX-1	HEX-2	T	Immersion tube (mm)
 <p>Coupling nut (standard)</p>	731A	G¼	22	-	7	Ø 6 to 8
	731B	G½	27	-	9	Ø 6 to 11
	731C	G¾	27	-	9	Ø 6 to 15
	731D	G1	32	-	9	Ø 6 to 20
	731E	G1	41	-	13	Ø 6 to 20
	731P	M18 x 1.5	27	-	8	Ø 6 to 12
	731Q	M20 x 1.5	27	-	9	Ø 6 to 14
	731R	M24 x 1.5	32	-	9	Ø 6 to 18
 <p>Coupling nut (long model)</p>	732C	G½	27	-	14	Ø 6 to 15
	732D	G¾	32	-	16	Ø 6 to 20
	732E	G1	41	-	18	Ø 6 to 20
 <p>Rotating nipple (standard)</p>	733A	G¼	17	-	12	Ø 6 to 8
	733B	G½	22	-	12	Ø 6 to 11
	733C	G¾	22	-	14	Ø 6 to 15
	733D	G1	30	-	16	Ø 6 to 20
	733E	G1	36	-	18	Ø 6 to 20
	733P	M18 x 1.5	22	-	12	Ø 6 to 12
	733Q	M20 x 1.5	22	-	14	Ø 6 to 14
	733R	M24 x 1.5	27	-	14	Ø 6 to 18
 <p>Rotating nipple (long model)</p>	734C	G½	22	-	20	Ø 6 to 15
	734D	G¾	30	-	20	Ø 6 to 20
	734E	G1	36	-	25	Ø 6 to 20

Process connections

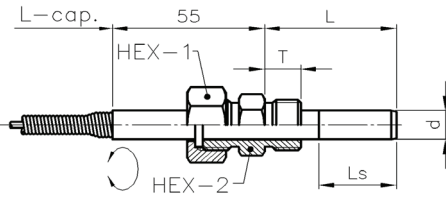
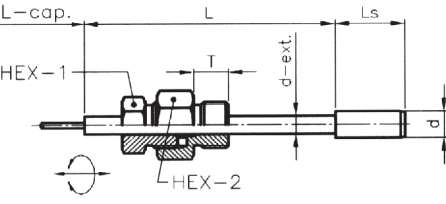
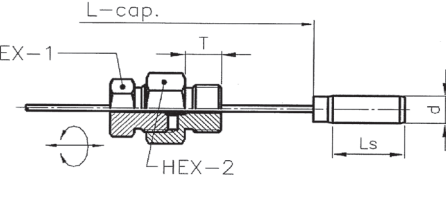
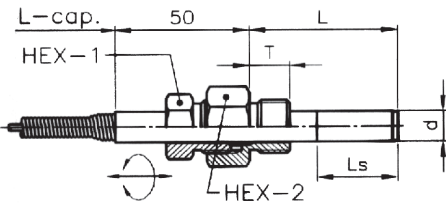
Models	Code	Connection	HEX-1	HEX-2	T	Immersion tube (mm)
 <p>Coupling nut + double nipple</p>	735A	G $\frac{1}{4}$	27	22	12	Ø 6 to 8
	735B	G $\frac{3}{8}$	27	22	12	Ø 6 to 11
	735C	G $\frac{1}{2}$	27	22	14	Ø 6 to 15
	735D	G $\frac{3}{4}$	27	27	16	Ø 6 to 20
	735E	G1	27	36	18	Ø 6 to 20
	735H	$\frac{1}{4}$ NPT	27	22	14	Ø 6 to 8
	735J	$\frac{1}{2}$ NPT	27	22	20	Ø 6 to 15
	735K	$\frac{3}{4}$ NPT	27	27	20	Ø 6 to 20
	735L	1" NPT	27	36	25	Ø 6 to 20
	735P	M18 x 1.5	27	22	12	Ø 6 to 12
	735Q	M20 x 1.5	27	22	14	Ø 6 to 14
	735R	M24 x 1.5	27	27	14	Ø 6 to 18
	 <p>Sliding connection on the extension tube</p>	736A	G $\frac{1}{4}$	22	27	12
736B		G $\frac{3}{8}$	22	27	12	Ø 6 to 14
736C		G $\frac{1}{2}$	22	27	14	Ø 6 to 18
736D		G $\frac{3}{4}$	22	32	16	Ø 6 to 23
736E		G1	22	36	18	Ø 6 to 30
736H		$\frac{1}{4}$ NPT	22	27	14	Ø 6 to 13
736J		$\frac{1}{2}$ NPT	22	27	20	Ø 6 to 20
736K		$\frac{3}{4}$ NPT	22	27	20	Ø 6 to 25
736L		1" NPT	22	36	25	Ø 6 to 32
736P		M18 x 1.5	22	27	12	Ø 6 to 16
736Q		M20 x 1.5	22	27	14	Ø 6 to 18
736R		M24 x 1.5	22	27	14	Ø 6 to 22
 <p>Sliding connection on the capillary</p>		737A	G $\frac{1}{4}$	22	27	12
	737B	G $\frac{3}{8}$	22	27	12	Ø 6 to 14
	737C	G $\frac{1}{2}$	22	27	14	Ø 6 to 18
	737D	G $\frac{3}{4}$	22	32	16	Ø 6 to 23
	737E	G1	22	36	18	Ø 6 to 30
	737H	$\frac{1}{4}$ NPT	22	27	14	Ø 6 to 13
	737J	$\frac{1}{2}$ NPT	22	27	20	Ø 6 to 20
	737K	$\frac{3}{4}$ NPT	22	27	20	Ø 6 to 25
	737L	1" NPT	22	36	25	Ø 6 to 32
	737P	M18 x 1.5	22	27	12	Ø 6 to 16
	737Q	M20 x 1.5	22	27	14	Ø 6 to 18
	737R	M24 x 1.5	22	27	14	Ø 6 to 22
	 <p>Sliding connection on the stem</p>	738A	G $\frac{1}{4}$	22	27	12
738B		G $\frac{3}{8}$	22	27	12	Ø 6 to 11
738C		G $\frac{1}{2}$	22	27	14	Ø 6 to 15
738D		G $\frac{3}{4}$	22	32	16	Ø 6 to 20
738E		G1	22	36	18	Ø 6 to 20
738H		$\frac{1}{4}$ NPT	22	27	14	Ø 6 to 8
738J		$\frac{1}{2}$ NPT	22	27	20	Ø 6 to 15
738K		$\frac{3}{4}$ NPT	22	27	20	Ø 6 to 20
738L		1" NPT	22	36	25	Ø 6 to 20
738P		M18 x 1.5	22	27	12	Ø 6 to 12
738Q		M20 x 1.5	22	27	14	Ø 6 to 14
738R		M24 x 1.5	22	27	14	Ø 6 to 18

Note: minimum immersion length: see table on page 6

Temperature ranges

Code	Range °C
69T	-200 ... 50
77T	-120 ... 40
76T	-100 ... 50
74T	-80 ... 40
68T	-70 ... 50
50T	-60 ... 40
65T	-40 ... 40
55T	-30 ... 170
51T	-30 ... 70
61T	-30 ... 30
84T	-20 ... 100
54T	-20 ... 60
52T	-20 ... 40
11T	0 ... 60
27T	0 ... 80

Code	Range °C
12T	0 ... 100
20T	0 ... 120
13T	0 ... 160
22T	0 ... 200
14T	0 ... 250
23T	0 ... 300
15T	0 ... 400
25T	0 ... 500
16T	0 ... 600
82T	0 ... 800
30T	100 ... 500

Code	Range °F
68U	-100 ... 120
09U	-50 ... 120
08U	-40 ... 160
02U	0 ... 200
03U	0 ... 250
04U	0 ... 300
05U	0 ... 400
06U	0 ... 500
20U	30 ... 250
13U	30 ... 320
22U	30 ... 400
23U	30 ... 580
15U	30 ... 750
28U	100 ... 800
29U	200 ... 1000

Code	Range (double scale)	
	°C	/ °F
51V	-30 ... 70	/ -40 ... 160
68V	-70 ... 50	/ -100 ... 100
55V	-30 ... 170	/ 0 ... 350
11V	0 ... 60	/ 30 ... 140
20V	0 ... 120	/ 30 ... 250
13V	0 ... 160	/ 30 ... 320
14V	0 ... 250	/ 30 ... 500
15V	0 ... 400	/ 30 ... 750
16V	0 ... 600	/ 100 ... 1100

Minimum immersion length Ls (mm)

Diameter of the Immersion tube (mm)							
Ø 6	Ø 8	Ø 9	Ø 10	Ø 11	Ø 12	Ø 14	Ø 16
70	35	30	25	20	18	15	13
120	60	45	35	30	25	20	17
190	90	60	55	45	35	30	25
-	135	100	80	65	55	40	30
-	170	130	100	80	65	50	40
-	-	190	150	120	95	70	55
Length of sensitive part Ls (mm)							

Capillary length (m)				
≤ 2	≤ 5	≤ 10	≤ 20	≤ 30
160	160	160	160	160
80	80	80	80	100
60	-	-	-	-
-	60	-	-	80
-	-	60	-	-
-	-	-	60	-
Min. temperature span (°C)				

How to use this table:

1. Select in the right table the first column, which covers your capillary length.
2. Move down in this column to the first value, which is not higher than your temperature span.
3. Move horizontal to the left table into the column with your selected immersion tube diameter.
4. Read the minimum length of the sensitive part of the immersion tube for your selection.

If this is too long, choose a larger diameter, a larger range or a shorter capillary.

Example:

4 m capillary, -20 ... 40 °C (span = 60 °C),
Immersion tube Ø 10 mm:
Minimum length of the sensitive part: Ls ≥ 80 mm

Standard version with plain immersion tube (without process connection)

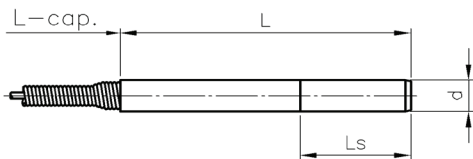

Ordering example with options

TSFE 100 - 2 61 . 1 B 2 . 20T . 30 . 5001 / 738C

- Gas filled thermometer with capillary and contacts
- Nominal size 100 mm
- Case material stainless steel 1.4301 (AISI 304)
- Support console for wall mounting, capillary outlet bottom
- Immersion tube diameter 8 mm
- Capillary stainless steel 1.4541 with stainless steel protection 1.4301 Ø 6 mm (up to 800 °C)
- Immersion tube, installed length L = 100 mm
- Temperature range: 0 ... 120 °C
- Length of capillary: 3 m
- Mechanical contact makes (NO) with clockwise pointer motion
- Option: Adjustable connection sliding on stem G½

Ordering details TSFE

	TSFE			-	2	xx	.			.	xxx	.	xx	.	xxxx	/	
Model	TSFE																
Gas filled thermometer with capillary and contacts																	
Nominal size																	
100 mm						1	0	0									
160 mm						1	6	0									
Case																	
Stainless steel 1.4301 (AISI 304)																	2
Type of mounting																	
Direct mounting, capillary outlet bottom																	11
Front flange for panel mounting, capillary outlet bottom																	21
Front flange for panel mounting, capillary outlet center back																	22
Rear flange for wall mounting, capillary outlet bottom																	31
Rear flange for wall mounting, capillary outlet center back																	32
U-clamp for panel mounting, capillary outlet lower back																	53
Support console for wall mounting, capillary outlet bottom																	61
Immersion tube diameter																	
6 mm																	4
8 mm																	1
9 mm																	A
10 mm																	B
11 mm																	2
12 mm																	C
14 mm																	7
16 mm																	D
Type of capillary																	
Stainless steel 1.4541 without protection, Ø 2.0 mm (up to 800 °C)																	6
Stainless steel 1.4541 with PVC, Ø 4.0 mm (up to 120 °C)																	7
Stainless steel 1.4541 with stainless steel protection 1.4301, Ø 6.0 mm (up to 800 °C)																	B
Stainless steel 1.4541 with stainless steel protection 1.4301 + PVC, Ø 7.5 mm (up to 120 °C)																	C
Immersion tube / installed length L																	
100 mm																	2
160 mm																	4
250 mm																	6
400 mm																	7
600 mm																	8
1000 mm																	9
Customer specific length (use option 9003_ xxxx, xxxx = L in mm)																	0
Unit of measurement / Temperature ranges																	
°C																	xxT
°F																	xxU
°C / °F (double scale)																	xxV
Length of capillary																	
1 m																	10
3 m																	30
6 m																	60
9 m																	90
12 m																	A2
15 m																	A5
20 m																	B0
30 m																	C0
Mechanical contacts (snap-action)																	
Contact makes (NO) ⁽¹⁾																	5001
Contact breaks (NC) ⁽¹⁾																	5002
Changeover contact (SPDT)																	5003
1 st contact makes / 2 nd contact makes (NO/NO) ⁽¹⁾																	5011
1 st contact makes / 2 nd contact breaks (NO/NC) ⁽¹⁾																	5012
1 st contact breaks / 2 nd contact makes (NC/NO) ⁽¹⁾																	5021
1 st contact breaks / 2 nd contact breaks (NC/NC) ⁽¹⁾																	5022
Double changeover contact (SPDT/SPDT)																	5033
1 st contact makes / 2 nd contact makes (NO/NO, separate circuits) ⁽¹⁾																	5055
1 st contact makes / 2 nd contact breaks (NO/NC, separate circuits) ⁽¹⁾																	5056
1 st contact breaks / 2 nd contact makes (NC/NO, separate circuits) ⁽¹⁾																	5065
1 st contact breaks / 2 nd contact breaks (NC/NC, separate circuits) ⁽¹⁾																	5066
Inductive contacts (Namur, DIN EN 60947-5-6)																	
Contact makes (NO) ⁽¹⁾																	8001
Contact breaks (NC) ⁽¹⁾																	8002
1 st contact makes / 2 nd contact makes (NO/NO) ⁽¹⁾																	8011
1 st contact makes / 2 nd contact breaks (NO/NC) ⁽¹⁾																	8012
1 st contact breaks / 2 nd contact makes (NC/NO) ⁽¹⁾																	8021
1 st contact breaks / 2 nd contact breaks (NC/NC) ⁽¹⁾																	8022
Options to be added behind the / (see example page 6)																	

⁽¹⁾ with clockwise pointer motion.